

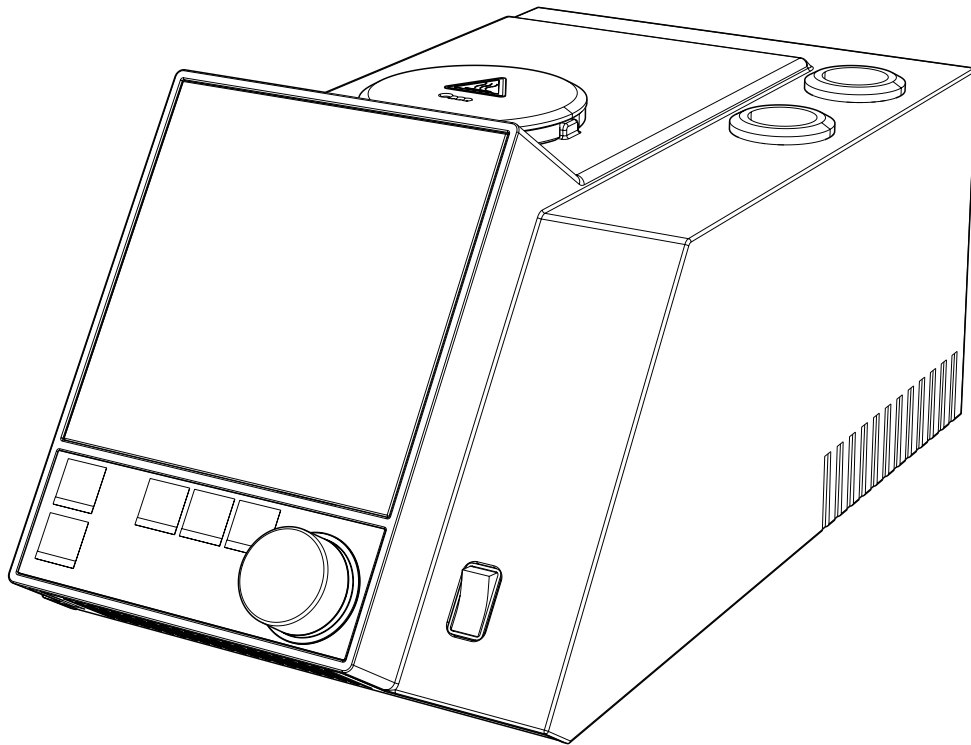

# Melting Point M-565

## Technical data sheet

The video camera equipped Melting Point M-565 for the automatic determination of melting and boiling points is designed for true, professional quality control. It includes a color display to observe the phase transition and a video function which allows for review of the determination. The Sample Loader M-569 allows a homogenous packing of capillaries providing highly reproducible results.



## Scope of delivery

Components	M-565	M-565 + M-569
Calibration set M-565/M-565	1	1
Melting point tubes 100 pcs.	1	1
Boiling point tubes 10 pcs.	1	1
Boiling capillary 10 pcs.	1	1
Sample holder	1	1
Cleaning tool	1	1
CD Demo MeltingPoint Monitor	1	1
Protection cover	1	1
USB cable 2.0 m	1	1
Operation Manual	1	1
Sample loader M-569	-	1

## Order code

1 1 0 5 8 0 0 4

Melting Point M-565

0 5 1 9 9 8

Melting Point M-565 + Sample Loader M-569

## Dimensions and weight

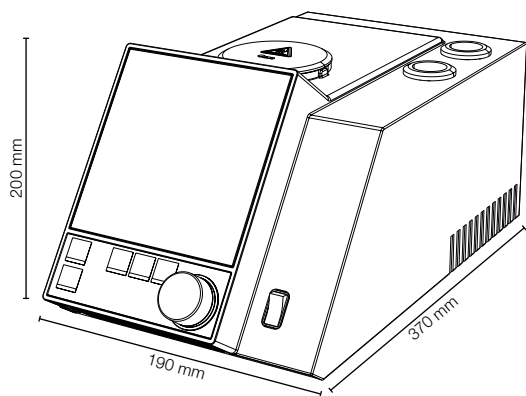

M-565

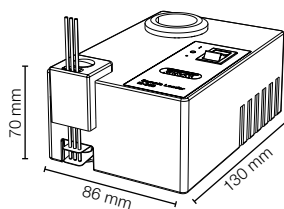

M-569

Dimensions (W x H x D)

Weight

Melting Point M-565	190 x 200 x 370 mm	4.5 kg
Sample Loader M-569	86 x 70 x 130 mm	0.5 kg

## Technical data

Positions for melting capillaries	3
Positions for boiling capillaries	1
Precision magnifying lens	1
Magnification of lens	2.5 x
Display	Colour, TFT, 320 x 240, 3.5"
Determination temperature range Ambient	Ambient + 10 °C to 400 °C
Temperature resolution	0.1 °C
Accuracy of the oven temperature at 0.5 °C/min	up to 250 °C ± 0.3 °C 250 °C to 400 °C ± 0.3 °C to ± 0.5 °C
Repeatability of melting point at 0.5 °C/min	± 0.1 °C
Accuracy of boiling point at 1.0 °C/min up to 400 °C	± 0.5 °C
Temperature gradients, °C/min	0.1, 0.2, 0.5, 1, 2, 3, 5, 10, 20
Heat-up time (50 °C – 350 °C) at 25 °C	~ 4 min
Cool-down time (350 °C – 50 °C) at 25 °C	~ 13 min
Electrical supply	100 – 240 V (± 10%) 50 – 60 Hz
Power consumption	150 W
Storable methods for melting point	50
Storable methods for boiling point	50
Compliant with Pharmacopeia methods	PH. EUR. 6.1.2.2.60, USP XXI 741 and JP
Interfaces	1 x PS/2 1 x RS232 1 x USB
Languages	en / de / fr / it / es / ja / cn

## Environmental conditions

Temperature	5 – 40 °C
Altitude	up to 2000 m a.s.l.
Humidity	maximum relative humidity 80 % for temperatures up to 31 °C, decreasing linearly to 50 % relative humidity at 40 °C
Overvoltage category	II
Degree of protection	IP20
Pollution degree	2

## Accessories

### Order number

MeltingPoint Monitor software with license	11055332
Sample Loader M-569	051997
Verification Kit M-560/M-565	11055019
Calibration Kit M-560/M-565	11055018
Agate mortar and pestle	041867
Compact keyboard German (CH)	029509
Compact keyboard English (USA)	029508
Serial printer	11055438
Ribbon for printer	044306
Paper roll for printer	038684
Sample holder	11055014
Cleaning tool	051978
Melting point capillaries, 1000 units	001759
Melting point capillaries, 100 units	017808
Boiling point tubes, 10 pcs.	019697
Boiling point capillaries 10 pcs.	051850
Boiling point tubes, 100 pcs.	019007
Boiling point capillaries 100 pcs.	051890
IQ/OQ Complete English	11055004
IQ/OQ Complete German	11055005
IQ/OQ Complete French	11055006
IQ/OQ Complete Spanish	11055007
IQ/OQ Complete Italian	11055008
OQ Repeating English	11055009
OQ Repeating German	11055010
OQ Repeating French	11055011
OQ Repeating Spanish	11055012
OQ Repeating Italian	11055013
Accelerated OQ English	11593454
Accelerated OQ German	11593455
Accelerated OQ French	11593456

## Functional principle

The Melting Point M-565 is an instrument for automatic and visual (manual) determination of melting point, melting range, and boiling point at ambient temperatures +10 °C up to 400 °C. The melting point of three samples can be determined at the same time. The boiling point can be determined for one sample. Samples can be observed through the lens or on the color display.

### Melting point

The melting point capillary sits in a hollow of a metal block, which is electrically heated and controlled by a temperature sensor. The heating block can be maintained accurately at a predefined temperature by the heating element and can be heated at a defined rate.

Detection is done as follows: The melting point capillary is illuminated from the front and the camera records the image. Melting and boiling points are detected by image processing.

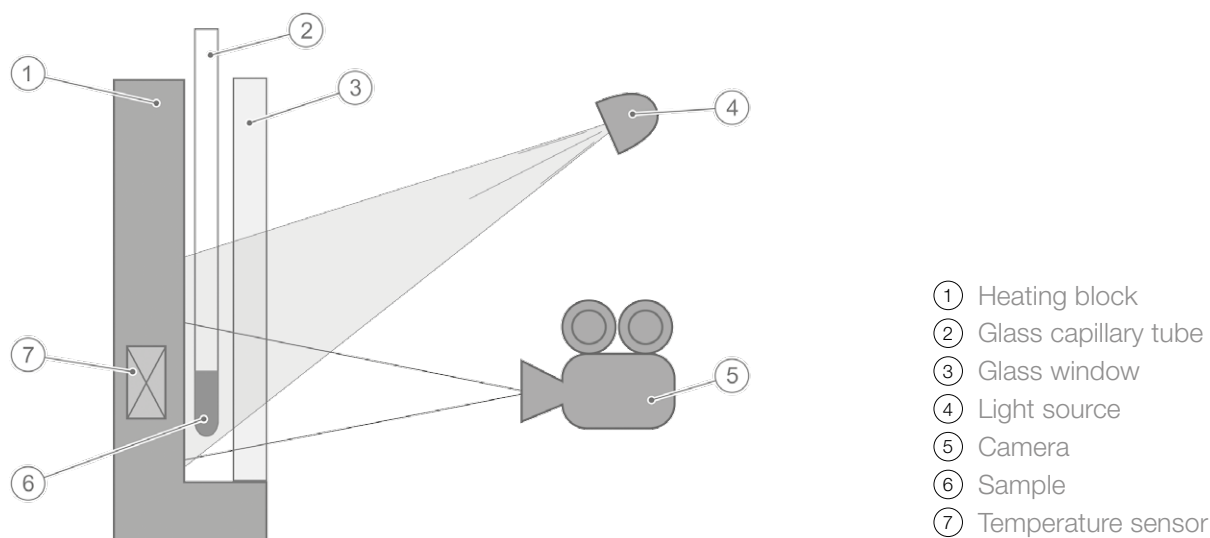

### Boiling point

The boiling point is determined by the “Siwoloboff” method. The Melting Point M-565 can be used to determine the boiling point of a small amount of liquid. The heating block has one insert available for boiling point tubes (outside left). The moment of boiling is determined automatically or visually.

Detection is done as follows:

- The beam of light illuminates the boiling point tube from the front, and the camera records the image.
- The boiling point of the liquid has been reached when the flow of steam bubbles reaches a frequency of 0.6 Hz [Hertz]

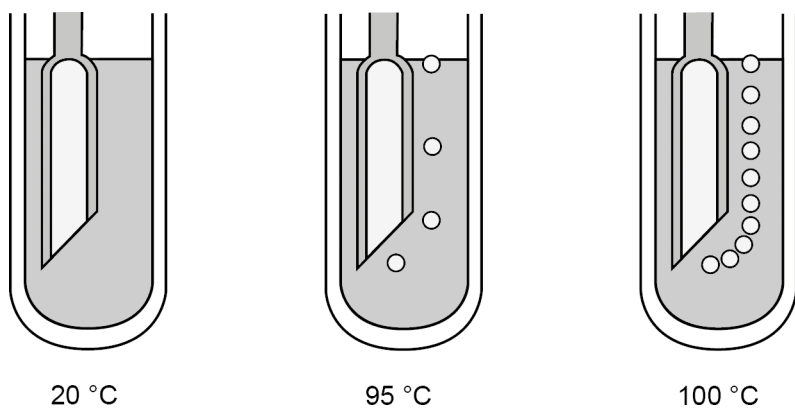

Boiling point determination: Schematic presentation of three steps

## MeltingPoint Monitor Software

The intuitive, user friendly management of methods, users and results in combination with the observation possibility of the melting or boiling movies, make the software essential for highly regulated routine work like in quality control. An observation of the melting curves and the melting video after the measurement localizes any failures in packing of the capillary, combustion of the substance or very impure substance and helps to reduce the number of repetitive measurements.

## Languages

MeltingPoint Monitor Software	en / de / fr / it / es / ja / cn
-------------------------------	----------------------------------

## Scope of delivery

### Melting Point Monitor Software

USB cable 2.0 m	1
MeltingPoint Monitor Software CD	1
Single license	1

## System requirements

The PC must fulfill the following requirements:

Operating System	Windows XP Professional (32 - bit only), SP3 or Windows 7 Professional / Ultimate / Enterprise (32 - bit or 64 - bit)
Central Processing Unit	Dual Core 2.4 GHz or faster
RAM	2 GB or more
Harddisk	> 15 GB of free harddisk space
Display resolution	1280 x 1024 (minimum 1024 x 768)
Interface	USB 1.1 or higher
Others	CD-ROM drive